



AGA ELECTRIC - AIMS EC3 COOKER



Users Instructions & Cooking Guide

PLEASE READ THESE INSTRUCTIONS BEFORE USING THIS APPLIANCE



10/08 EOP1 515270

CONTENTS

SECTION	PAGE
HEALTH & SAFETY	3
THE AGA COOKER	4
OPERATING THE AGA	5
BAKING OVEN	6
FITTING OF OVEN SHELVES	7
REMOVAL OF OVEN SHELVES	8
GUIDE TO AGA COOKING	9
POWERED OVEN VENTING	9
AIMS SET-UP	10
AIMS CONTROLLER HANDSET	10 - 11
INFORMATION (MAIN MENU) SCREEN	12
SETTINGS DATE/TIME SCREEN	12
AIMS PROGRAMME SCREEN	13
HOLIDAY SCREEN	14
CARING AND CLEANING	15
AIMS HANDSET CARE	16
SERVICING	17

HEALTH & SAFETY

Consumer Protection

As responsible manufacturers we take care to make sure that our products are designed and constructed to meet the required safety standards, when properly installed and used.

This appliance is not intended for use by persons (including children) with reduced physical, sensory or mental capabilities, or lack of experience and knowledge, unless they have been given supervision or instruction concerning use of the appliance by a person responsible for their safety.

Children should be supervised to ensure that they do not play with the appliance.

IMPORTANT NOTICE: PLEASE READ THE ACCOMPANYING WARRANTY.

Any alteration that is not approved by Aga could invalidate the approval of the appliance, operation of the warranty and could also affect your statutory rights.

APPLIANCE

YOUNG CHILDREN SHOULD BE KEPT AWAY FROM THE APPLIANCE AS SURFACES CAN BECOME HOT TO THE TOUCH.

Deep Fat Frying

IMPORTANT

- Use a deep pan.
- Never fill the pan more than one-third full of fat or oil.
- Never use a lid on the pan.
- Important: Oil is a fire risk, do not leave pans containing oil unattended.
- In the event of a fire, cover the pan with a lid and turn OFF the appliance.

Smother the flames on the hob preferably with a fire blanket, rather than attempting to remove the pan to the outside.

Burns and injuries are caused almost invariably by picking up the burning pan to carry it outside.

- **Do not hang clothes over the left hand side of the Aga hand-rail, because the electrical controls are behind the top left hand door, and will prevent easy access to the controls.**

THE AGA COOKER

This appliance is a heat storage cooker with a 13 amp element which will keep the temperature of the cooker constant when not in use and return it to constant temperature after use or in accordance with pre-set AIMS programme.

The Aga EC3 cooker has three ovens, namely, the Roasting Oven, Baking Oven and Simmering Oven. 'Grilling' and 'frying' can be done in the top and floor positions in the Roasting Oven.

The Aga is supplied with the following accessories:

- 1 Large roasting tin with grill rack
- 1 Half-size roasting tin with grill rack
- 3 Oven grid shelves
- 1 Plain shelf
- 1 Toaster
- 1 Aga book
- 1 Wire brush
- Samples of enamel and chrome/stainless cleaner

In addition there is a guarantee registration card which should be completed and returned to Aga.

A full description of cooking with the Aga is given in the Aga Book.

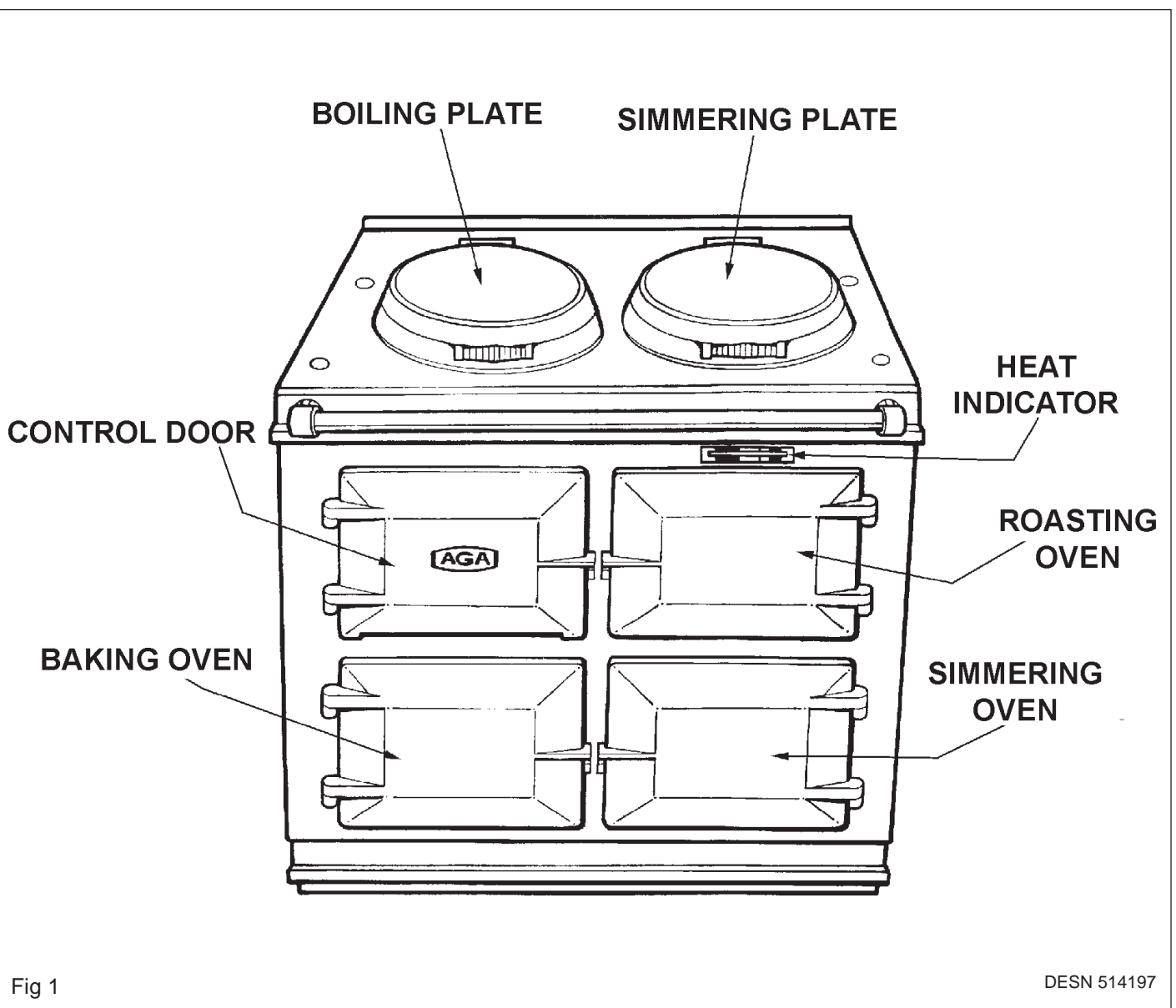

Fig 1

DESN 514197

OPERATING THE AGA

The following points are intended to help during the change-over from a previous cooker to the Aga. The Aga Book and the Aga new user guide video provide a very useful introduction to the cooker.

After the Aga has been installed

When first switched on, the Aga will emit an odour for a short while. This is simply due to protective oil burning off the hotplates. Wipe the inside of the lids whilst the Aga is heating up to avoid a film of this oil being deposited on the inside of the lids. Also, condensation may occur on the top and front plate whilst the Aga is heating up. This should be wiped away as soon as possible.

The Heat Indicator

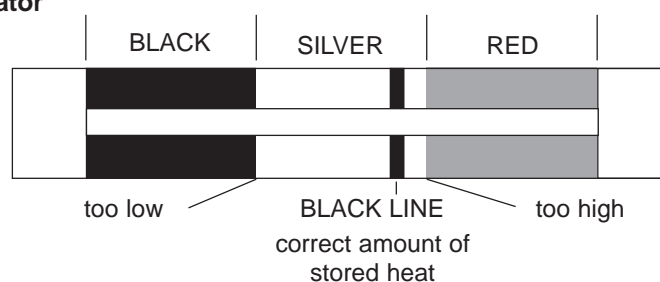

Fig. 2

The heat indicator is above the Roasting Oven door and has three sections: black, silver and red. When the indicator is on or around the black line in the silver section the cooker is at the correct working temperature. The purpose of the heat indicator is to show whether the cooker contains the full amount of stored heat when the cooker is in normal operational mode. During cooking the indicator line will drop back. This is normal and the heat will be automatically restored.

NOTE: IT DOES NOT INDICATE THE OVEN TEMPERATURE

For most effective operation of the cooker the following points should be carefully observed:

1. Close the insulating covers whenever the hotplates are not in use.
2. Clean the hotplates regularly with the wire brush.
3. Utensils with ground flat bases must be used to make perfect contact with the hotplates.
4. Have the cooker serviced at regular intervals by your Aga Specialist.
5. Take care when closing the oven doors, to lift them on to the catch.
6. Cook as much as possible in the ovens, so that heat is conserved and cooking smells and condensation are reduced.

The Roasting Oven can also be used for 'grilling' at the top and shallow 'frying' on the oven floor. Keep the insulated covers down when the hotplates are not in use so that the heat stored in the cooker is conserved.

- For optimum cooking performance, use the Aga utensils and cast iron cookware. They have thick ground bases which give the best contact with the hotplates.
- The Aga pans can be stacked in the Simmering Oven. This is especially useful for steaming vegetables and keeping sauces warm.
- Store the Plain Shelf out of the Aga. Use it cold in the Roasting Oven to deflect the heat from the top of the oven, creating a more moderate oven temperature underneath. It can also be used as a baking sheet.
- A guide to Aga cooking is given on Page 9. Ask the Aga Specialist for an invitation to an Aga demonstration.

BAKING OVEN

WHEN USING ALL OF THE OVENS AND HOTPLATES TOGETHER FOR A LONG PERIOD OF TIME i.e. full meal.

In the above case, the Baking Oven temperature may rise, it will therefore be necessary to adjust the cooking procedure, the following suggestions may prove useful:

1. When placing the food in the Baking Oven, ensure that the cold Plain Shelf is set directly above the dish, for the whole of the cooking time.
2. In addition it may be necessary to lower the shelf position.
3. When baking food, such as very rich fruit cakes, which require a long period of cooking time, place the cake on the fourth grid shelf position of the oven with the cold plain shelf set directly above, for 3/4 hour approximately. Move the plain shelf to the middle of the Simmering Oven. Transfer the cake to this shelf and bake until cooked through.
4. Alternatively, allow the Baking Oven to cool for approximately 4 hours before using.

NOTE: A loose metal plate is positioned in the top of the Baking Oven in order to optimise cooking performance. It must remain in place at all times while the cooker is in operation.

FITTING OF OVEN SHELVES

When using the oven shelves for the first time follow Figs. 3 - 6.

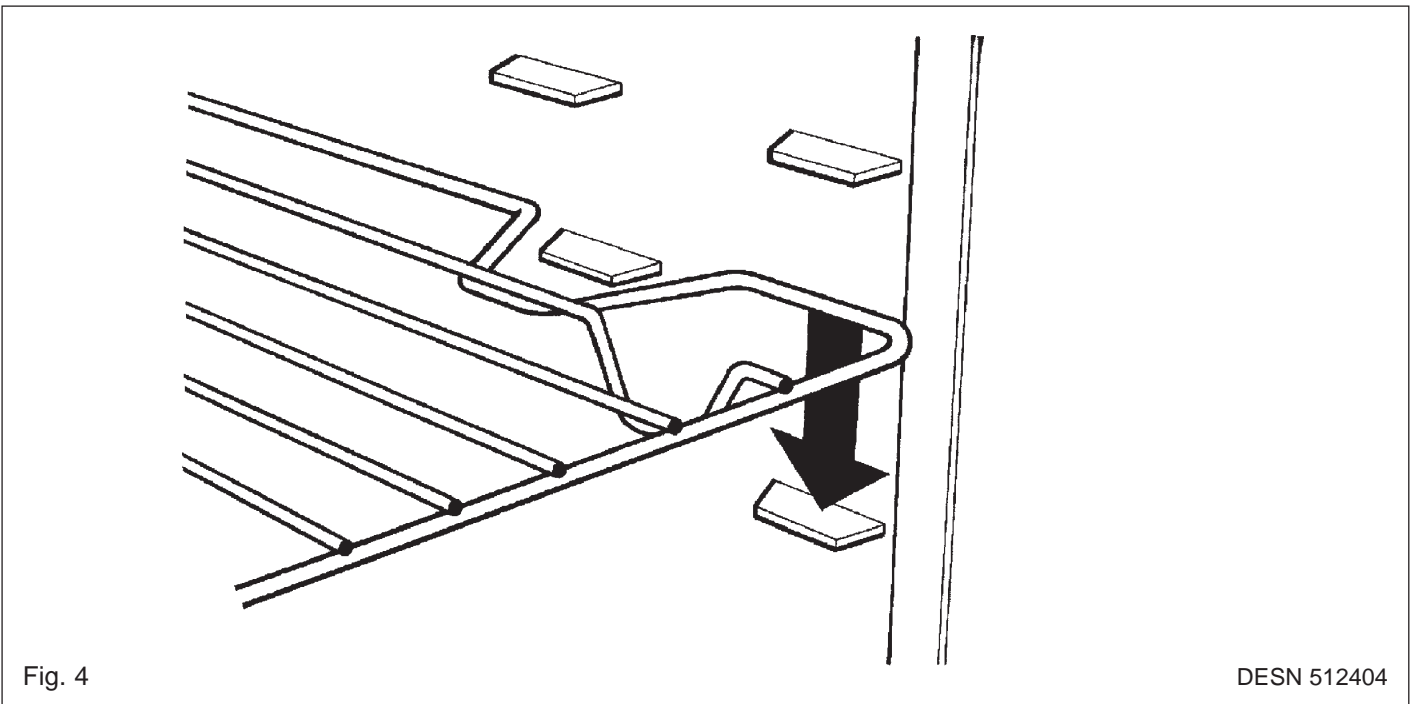
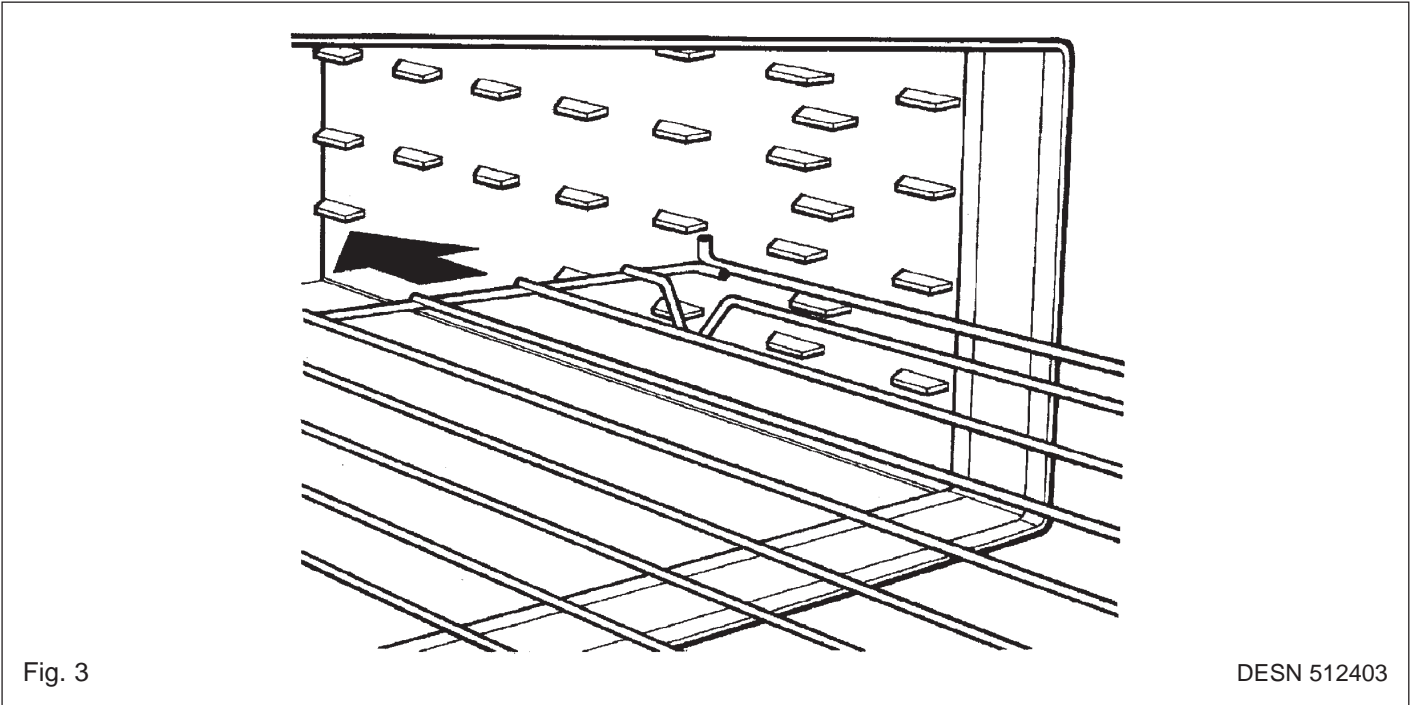

REMOVAL OF OVEN SHELVES

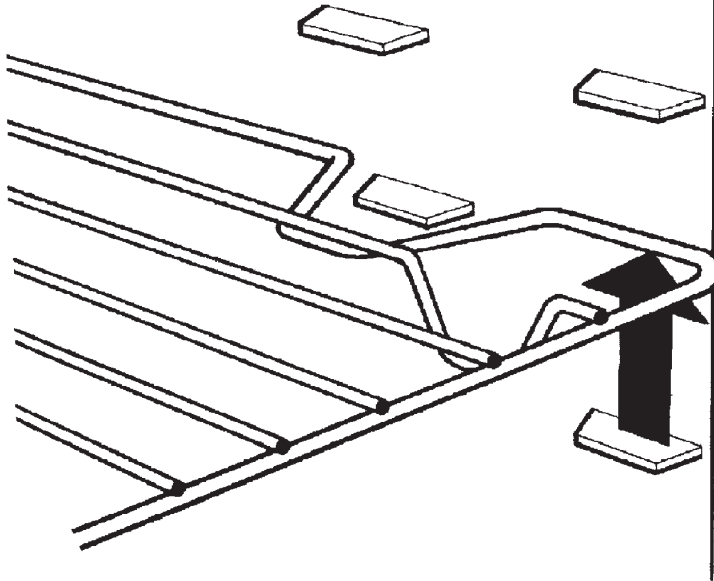

Fig. 5

DESN 512405

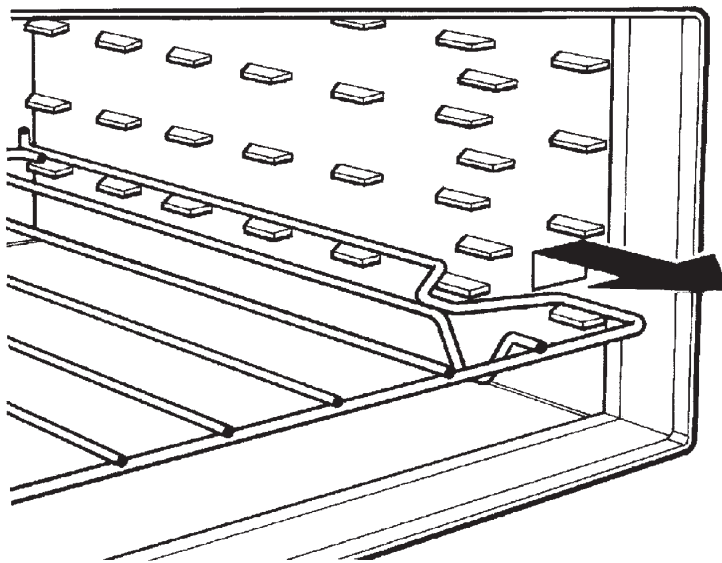

Fig. 6

DESN 512406

GUIDE TO AGA COOKING

As the Aga is heated differently from an ordinary appliance, exact conversions are not possible. Look in the Aga book for a similar recipe. Below is a quick guide to oven usage.

OVEN TEMPERATURE	AGA OVENS
HIGH	ROASTING OVEN
GRILLING SCONES PASTRIES BREAD YORKSHIRE PUDDING ROASTS SHALLOW FRYING	Top - grilling 2nd runner - scones, small pastries; 3rd runner - bread rolls, Yorkshire pudding; 4th runner - roasts, poultry, small cakes in cases in the large meat tin. Grid shelf on oven floor - loaves. Oven floor - shallow frying, quiche.
MODERATE	BAKING OVEN
CAKES BISCUITS FISH SOUFFLÉS SHORTBREAD CHEESECAKES	Towards top - whisked sponges, some biscuits, small cakes Middle - fish, soufflés. Grid shelf on oven floor - Victoria sandwiches, shortbread and cheesecake
LOW	SIMMERING OVEN
CASSEROLES STOCK MILK PUDDINGS MERINGUES RICH FRUIT CAKE	For casseroles, stock, milk puddings, bring to heat elsewhere on the Aga then transfer to Simmering Oven. (One exception is meringues). Rich fruit cakes can be cooked for a long time here

POWERED OVEN VENTING

Roasting, Simmering and Baking Ovens

This feature is fitted to your cooker, it should be used as follows:

After placing the food to be cooked in the oven, depress the switch on the remote control, a light will appear behind the bottom left hand door, the fan will be activated and the cooking smells will be vented to outside.



REMEMBER: SWITCH THE FAN OFF WHEN YOU HAVE FINISHED COOKING.

AIMS (AGA INTELLIGENT MANAGEMENT SYSTEM)

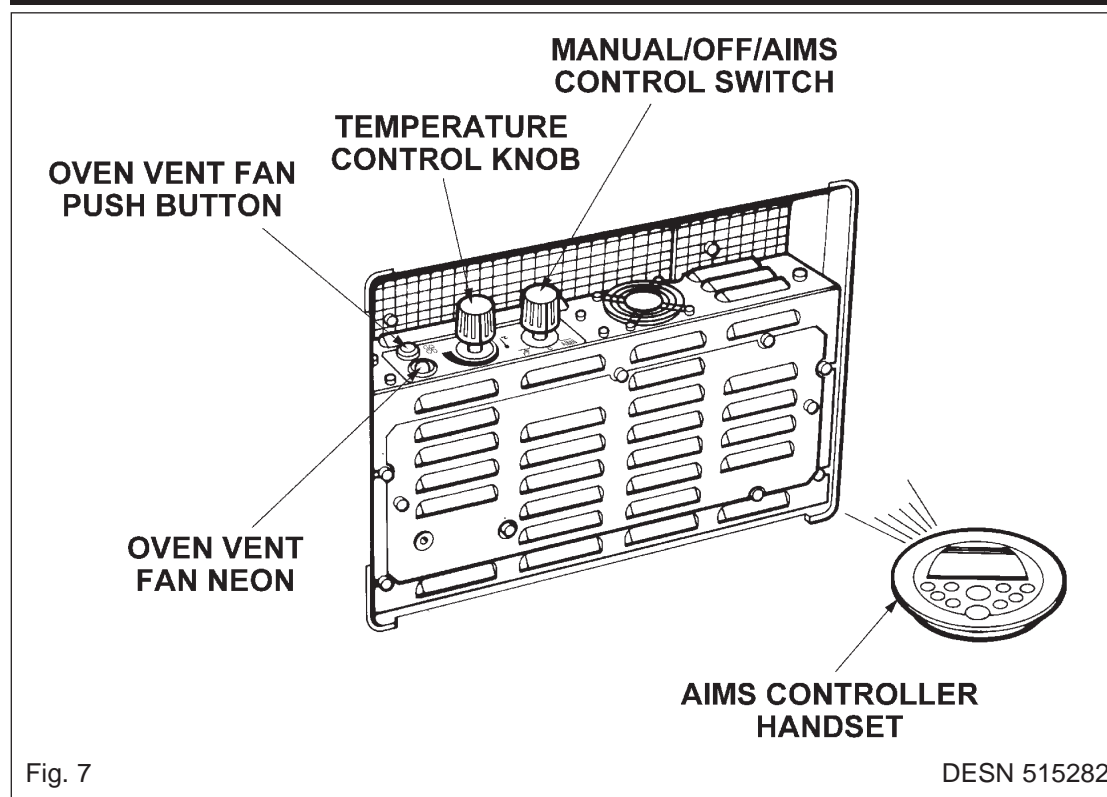
CONTROLS



AIMS SET-UP (SEE FIG. 7)

1. Connect the electricity supply.
2. Turn the right hand control knob from the OFF setting to the  Normal manual control setting. The cooker will heat up until it reaches the Normal temperature as indicated by the black line on the heat indicator.
3. The left hand control knob will alter the oven temperature. Turn it clockwise to increase the temperature and anti-clockwise to decrease the temperature.
To obtain the required roasting oven temperature of 240°C this control knob will need to be set about halfway. We recommend that the cooker is run on the  Normal manual setting for two days, before switching to AIMS (automatic control).
4. When the Normal temperature has been set with heat indicator on or near the black line, it should not be necessary to alter the temperature control again.
5. The cooker can now be switched to AIMS (automatic control), by turning the right hand control knob from the  setting to the AIMS setting.
6. The AIMS hand set can then be used to programme the required settings (see AIMS (automatic)) control instructions.

AIMS CONTROLLER HANDSET

The handset is designed to operate within the kitchen area.

When transferring information from or to the controller always operate the handset in front of the cooker, this gives the strongest signal.

If the handset indicates 'OFFLINE', press the back button  firmly, this will activate the communication link between the cooker and handset.

Should the handset continue to show 'OFFLINE', allow one minute for the handset to "automatically", re-connect itself with the cooker.

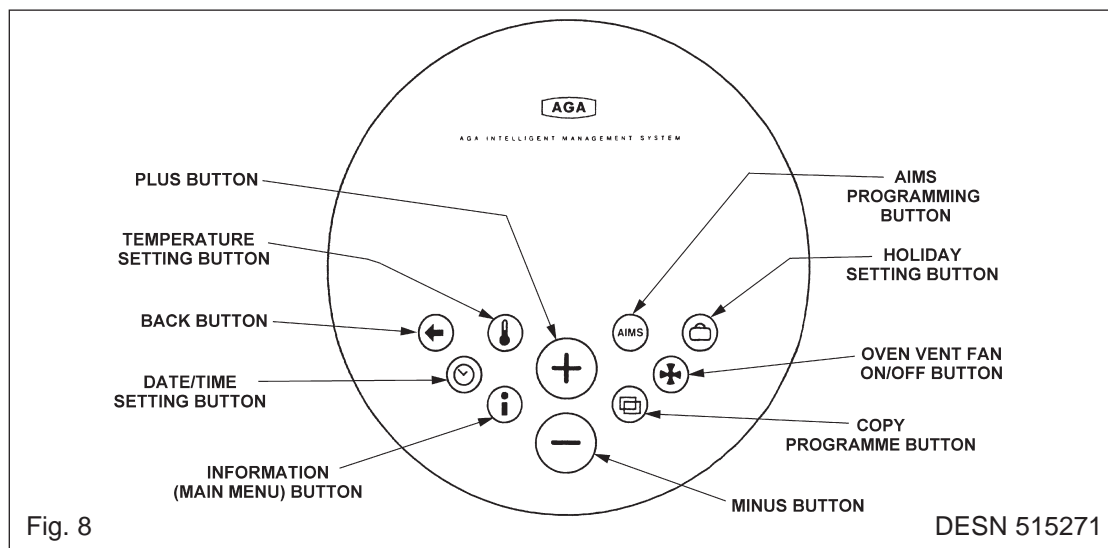

The handset has 10 buttons and a display screen.

NOTE: If the AIMS handset is unused for an extended period of time, the display screen will automatically turn OFF to conserve battery power. The controller is designed to be operated within the kitchen area.

Press firmly any button on the handset to turn the display back on, and the Information (main menu) screen is automatically displayed.

The AIMS Controller handset has four display screens:

1. The Information (main menu) screen
2. The Date/Time setting screen
3. The AIMS Programme screen
4. The Holiday Setting screen

See each section for details.

The AIMS has one or two programmable events:

The two events programme will enable the Aga to be at 'Normal' in the morning, (ie to cook breakfast) drop to a lower temperature during the day, and return to 'Normal' temperature in the evening (ie: to cook dinner) and drop to 'Slumber' later in the evening and throughout the night.

The one event programme will enable the Aga to drop to 'Slumber' during the night and return to 'Normal' throughout the day.

This will be shown as Once or Twice on the AIMS programme screen. (See Fig. 11).

The 'Normal' temperature for those two events can be set using the cooker thermostat.

The modes in between the events can be set at 'Low' or 'Slumber' depending on personal preference.

If a mistake is made when setting the date or time on any of the screens, use the back button  to go back to previous setting.

When the oven vent fan button  is pressed the oven vent fan will be switched on and a blue light will appear.

SELECTING HANDSET LANGUAGE

Language options are selected during the **Handset to Base Unit Signal Check/Language Selection** procedure, see page 16.

INFORMATION (MAIN MENU) SCREEN

Press the  button to activate this screen

Indicates that the cooker is operating automatically (AIMS) or manually (according to switch position on main Aga control panel)

This indicates the current cooker mode, (Normal, Low or Slumber). If an arrow is showing → this indicates the cooker is heating up from Low or Slumber to Normal.

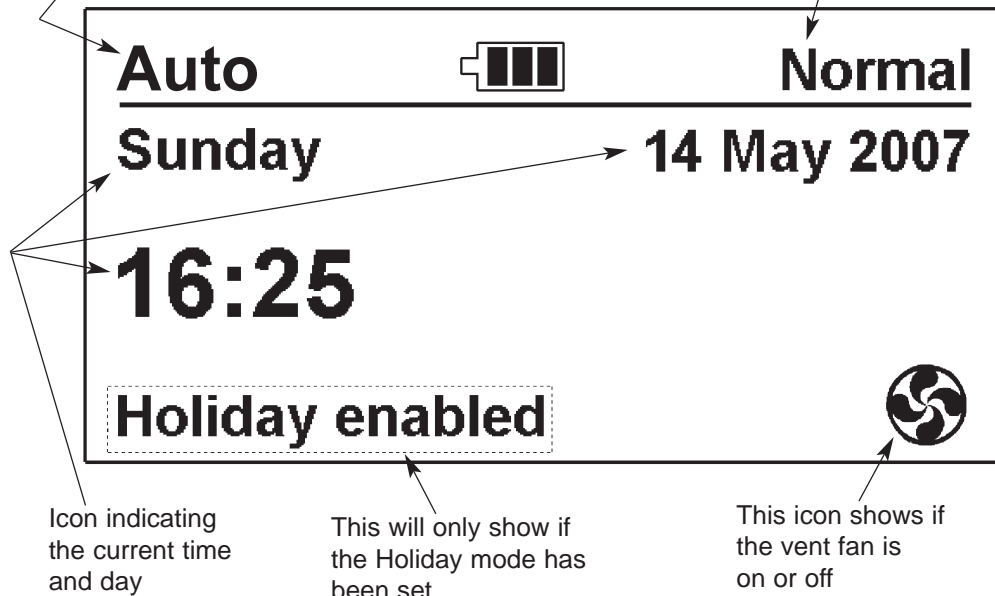





Fig. 9

DESN 515272

THE SETTINGS DATE/TIME SCREEN

Press the  button to activate this screen

1. Press the  button to move between the date and time.
2. Press + or - to alter date and time settings.
3. Press the  button to confirm the settings and move to the next action

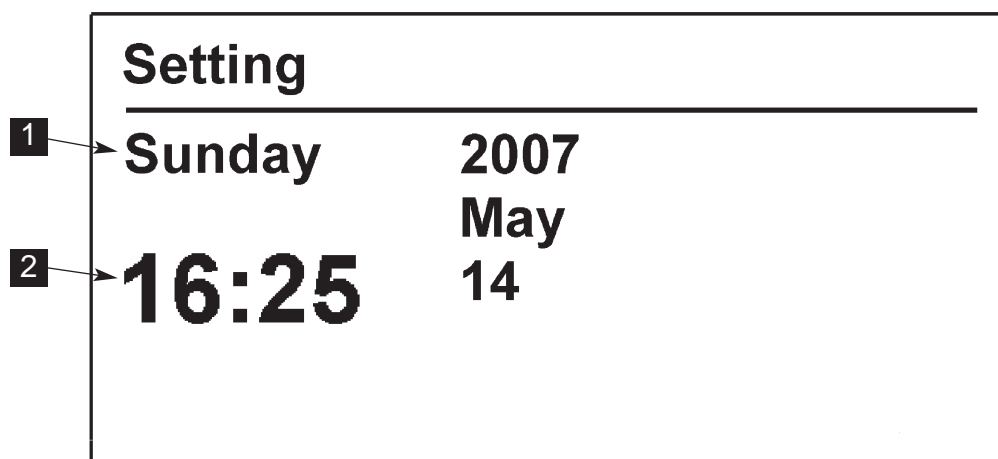











Fig. 10

DESN 515273



AIMS PROGRAMME SCREEN

Use the  button to activate this screen and to move through the different actions and set an AIMS programme. To go back a step at any time press .

1. Set the frequency of the programme Once or Twice daily using + and - buttons.
2. Press  button to select start time for 'Normal' setting then use the + or - buttons to set start time.
3. Press the  button to select finish time then use + and - buttons to set finish time. When a time is selected it will be highlighted in dark blue.
4. Press the  button then press the  button to alter the temperature setting to 'Low', 'Slumber', or 'Off'. (Repeat steps 2 - 4 to set a 2nd event)
To copy this days settings for the next day press the  button or alternatively press the  button to enter different settings for next day.

Each push of the copy button steps onto next day. When the desired days have been programmed a return must be made to the main menu screen by pressing the  button. A '**Please Wait**' message will display to confirm changes are being sent to the base unit.

If the programme is not set for the whole week the programme for the remaining days will revert to a default setting. ie: 8:00 am - 9:00 am and 18:00 - 19:00.

To change a setting within the AIMS program, press the  button until the desired setting is reached. Then change setting using either the +, - or  buttons as appropriate.

If no other changes are to be made, push the  button to transmit the change (s) and return to main menu. A message saying '**Please Wait**' will display, indicating that the changes are being transmitted to the base unit. Unless this shows, the changes will not have been implemented.

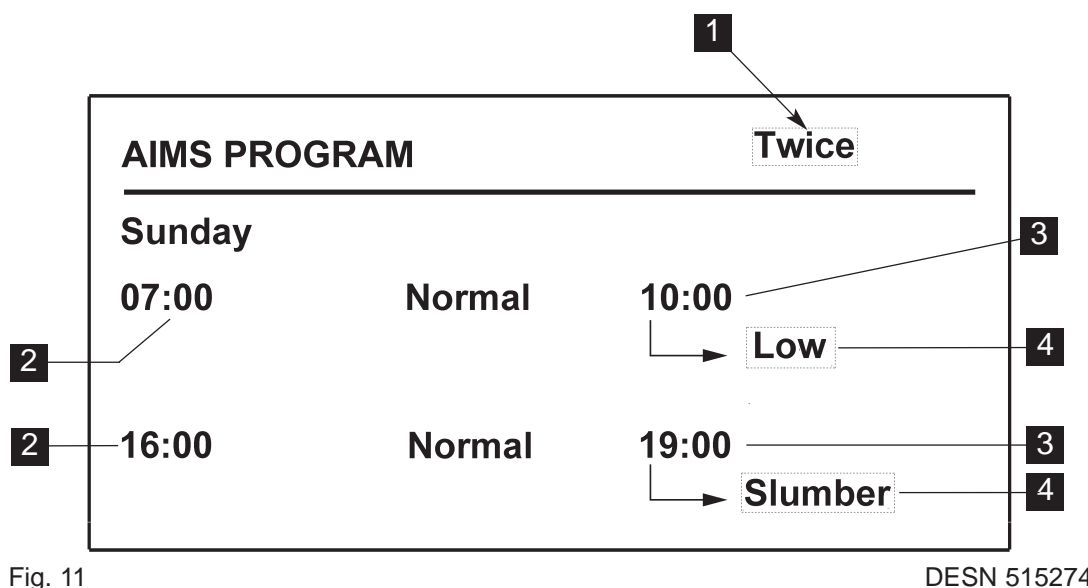



Fig. 11

DESN 515274

This screen shows that the ovens will be up at 'Normal' temperature between 07:00 and 10:00 the ovens will then go to the 'Low' mode.





The ovens will come up to 'Normal' once more in that day i.e. at 16:00 until 19:00. After the evening the system will automatically enter 'Slumber' mode its lowest setting until next morning.

Boost

If cooking is required when the Aga is in the **AIMS** programme i.e 'Low' or 'Slumber', you can boost the cooking temperature by pressing the  Button which will bring the Aga upto 'Normal' operating temperature. This will take up to 2 hours from 'Low' and 4 hours from 'Slumber'.

THE HOLIDAY SCREEN

Press the  button to activate this screen and to move through the different operations and set a holiday programme.

1. Set a start date and time using the + or - buttons. Pressing the  button after each field has been entered to move you to the next field.
When a field is selected it will be highlighted in dark blue.
2. Set an end date and time using the + or - buttons. Pressing the  button after each field has been entered to move you to the next field.
3. Press the  button to alter the temperature setting to 'Low', 'Slumber' or 'Off'
When all the settings are completed press the  button again to enable the Holiday programme.
The display will return to the Main Menu Screen.

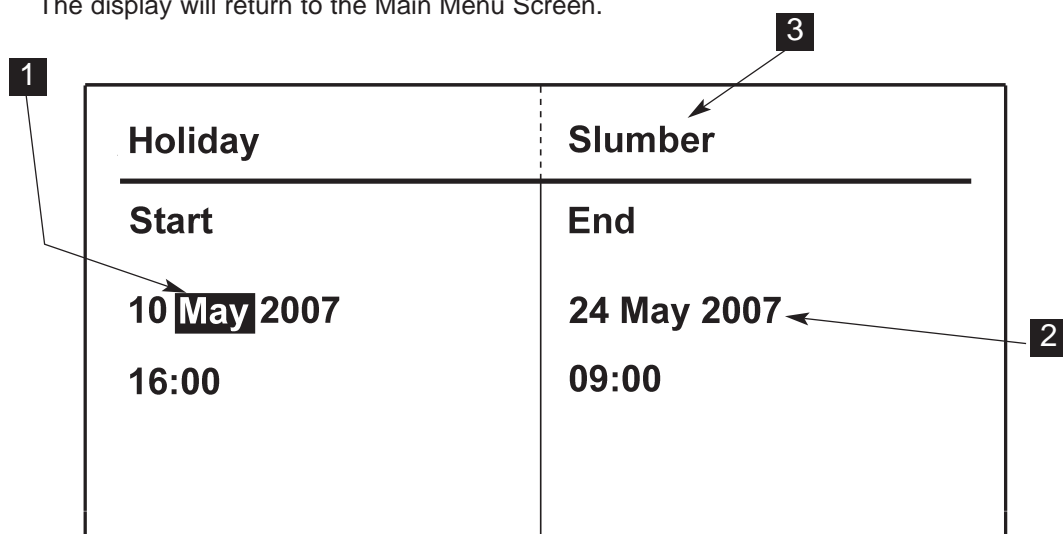



Fig. 12

DESN 515275

Once a holiday mode has been set it will show as 'Holiday Enabled' on the main menu screen.

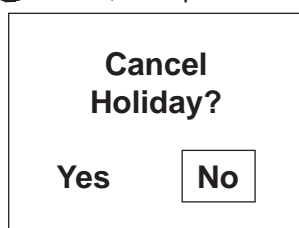

If you wish to cancel the holiday setting:

Press the  button, then press the  button and the following screen will appear:



Select YES using the  button, then return to  main menu screen.

If you wish to alter a holiday setting:-

Press , alter setting (use + or - then ), then after last setting press  again to return to main menu screen.

In event of a power cut

If mains power is lost/or disconnected for more than 15 minutes, when the power is restored the handset will display:-

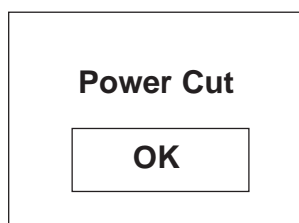

By then pressing the , this will send the correct time/date settings to the base.

CARING AND CLEANING

REMEMBER: BE CAREFUL OF THE HOT APPLIANCE.

DO NOT USE A STEAM CLEANER TO CLEAN THIS COOKER.

DO NOT USE ABRASIVE PADS OR OVEN CLEANERS.

Top Plate and Front Plate

The easiest way to clean the Aga top plate and front plate is to mop up spills as soon as they happen. Baked-on food is more difficult to clean but can usually be removed with the Aga vitreous enamel cleaner or mild cream cleaners using a damp cloth, or, if necessary a nylon scouring pad. If milk or fruit juice or anything containing acid, is spilt on the Aga, wipe it up immediately. Also clean off any condensation streaks on the front plate around the oven doors or the vitreous enamel maybe permanently discoloured.

All that is usually needed to keep the vitreous enamel surfaces of the Aga bright and clean is a daily rub over with a damp soapy cloth followed immediately with a clean, dry cloth to avoid streaks.

Remember the top plate and the polished covers will scratch if pans or utensils are dragged across them.

Insulating Covers and Oven Doors

The linings of the insulating Covers and oven doors may be cleaned with a cream cleanser or a soap impregnated pad.

Open the covers and lift off the oven doors to allow them to cool a little before cleaning. Do not, however, immerse the doors in water as they are packed with insulating material which will be damaged by excessive moisture.

Refer also to the Cleaning Section in The Aga Book.

Ovens and Hotplates

The cast iron ovens help to keep themselves clean, they merely need to be brushed out occasionally with a long handled stiff brush.

The wire brush is provided for cleaning the hotplate and any burnt on spills in the cast iron ovens.

Roasting Tins

The enamelled roasting tins supplied with the new Aga should be cleaned in hot soapy water, soaking if necessary. A nylon scouring pad can also be used. They may also be cleaned in the dishwasher but, with constant use, the enamelled finish will become dull in appearance.

DO NOT use caustic cleaners or oven cleaners.

Important: Aga recommend Vitreous Enamel Association approved cleaners for cleaning the vitreous enamelled surfaces of this product.

They are unsuitable for use on: chrome and stainless steel components, including the insulating covers, hand-rails and their brackets.

The insulating covers should be cleaned regularly with a NON-ABRASIVE mild detergent, applied with a soft (coarse free) cloth and lightly polished up afterwards with a soft (coarse free) duster or tissue, to bring it back to its original lustre.

AIMS HANDSET CARE

Operating Distance

The Handset will only operate in the same room as the appliance and up to a maximum distance of 4 metres from the appliance. If out of recommended operating range, the handset may show "OFFLINE". Move handset back to within the recommended distance and the handset should correct itself. See note at foot of this page for "Handset to Base Unit Signal Check".

Cleaning

The Handset should be wiped clean using a soft clean cloth.
Do not use abrasive cleaning products or submerge the Handset in water.

Batteries

The Handset is fitted with four 'AAA' batteries.

Batteries life will depend on usages.

Replace the batteries when the battery symbol on the Handset is down to one bar following the instructions below.

- Remove the Handset from the backplate.
- Remove the battery cover plate from the rear of the Handset (fig 13)
- Carefully lever out the batteries commencing with the bottom one first pushing and pulling out on the **positive (+) end only** (fig14).
- Repeat the procedure to remove the other batteries.
- **Always** use long life batteries for replacements.
- Replace batteries commencing with the bottom one working to the top (fig 15) Ensure that the negative (-) end of the batteries is under the location pegs in the housing before pushing the other end into position.

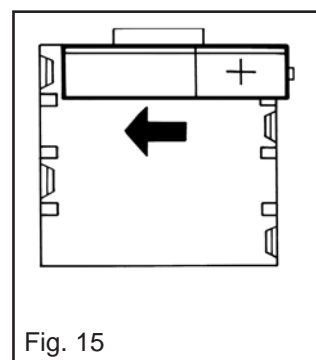
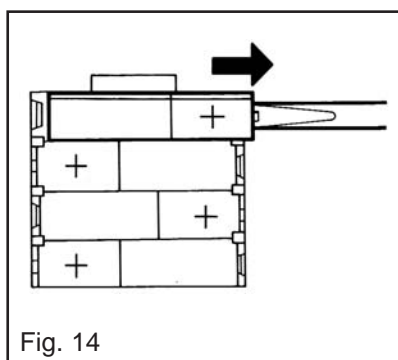
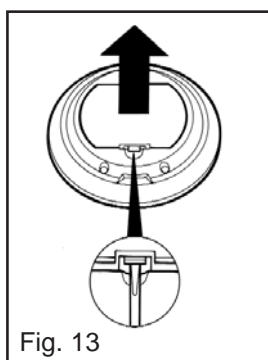

Handset Failure

In the event of Handset failure, the appliance would still be operational with the last selected programme. The appliance can also be changed to manual mode if required using the control knob (see fig 7).

If the Handset is damaged or lost, replacement can be obtained from Aga and re-programmed to suit your appliance.

Handset to Base Unit Signal Check/Language Selection

Complete the following procedure to check the handset is communicating with the base unit and to select a language option.

1. Press and hold the oven vent fan button on the control panel **in the Aga** until the blue neon vent fan indicator flashes, then release button.
2. Immediately after neon starts to flash press and hold the **+** and **-** buttons together on the handset until the blue neon goes out completely (handset display will briefly say connect), then release buttons.
3. If the neon does not extinguish completely, but continue to flash with faint output, then repeat steps 1 and 2 above.
4. When the connection has been made, the screen will display the language options, use the **+** or **-** buttons to scroll through the options to the desired language, then press the  button to confirm selection.
5. If the language option needs to be changed at any time then the whole procedure must be repeated from step 1.

SERVICING

- In the event of your appliance requiring maintenance, please contact Aga Service or your Aga Specialist.
- Your cooker must only be serviced by a qualified engineer, from an authorised Aga Specialist.
- Do not alter or modify the cooker.
- Only the spares specified by the manufacturer, are to be fitted.

For continued efficient and safe operation of this part of the appliance, it is important that servicing is carried out at regular intervals as recommended by your Aga Specialist, once every 5 years. The cooker should be turned OFF by the user the night preceding the day of servicing so that the appliance will have cooled down by the following morning.

A HOT APPLIANCE CANNOT BE SERVICED.

For further advice or information contact your
local Aga Specialist

With Aga's policy of continuous product
improvement, the Company reserves the right to
change specifications and make modifications to
the appliance described and illustrated at any time.



Manufactured By
Aga
Station Road
Ketley Telford
Shropshire TF1 5AQ
England

www.aga-web.co.uk
www.agacookshop.co.uk
www.agalinks.com